

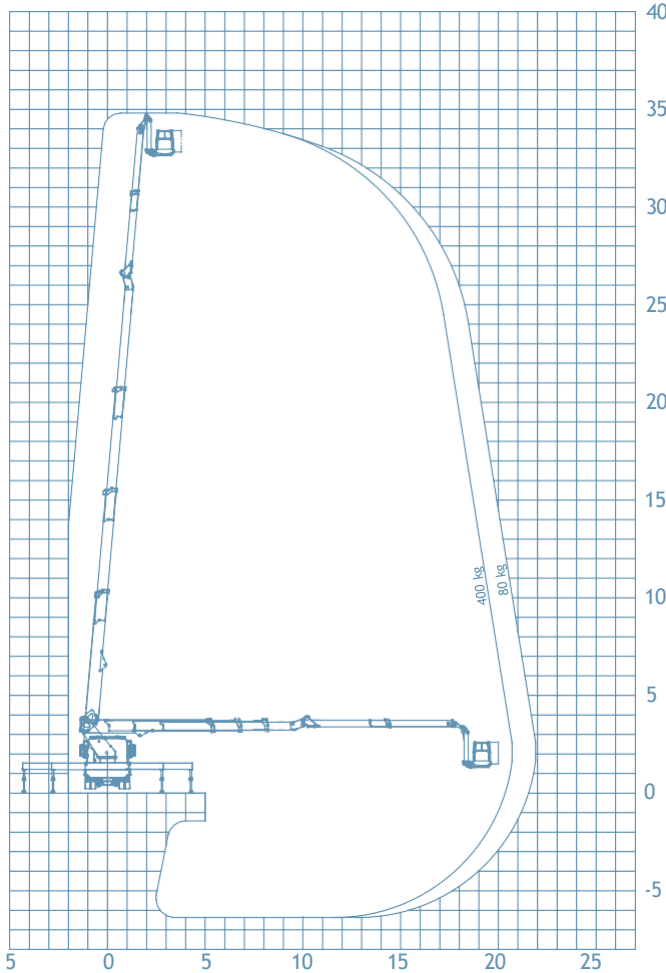

for Site 35TJ

WORKING DIAGRAM



STANDARD ACCESSORIES

DATA SHEET

- Extendable aluminum basket with dimensions 2300/3600 x900x1100 mm
- SOCAGE convertible basket possibility (Eternit)
- Basket rotation 360°
- Rotation turret 700°
- Possibility of winch on removable JIB
- Automatic stabilization
- Partially stabilized work areas
- Automatic closing
- Basket control station with console on Socage design including joystick and 7" LCD display with real-time information
- Intercom with headphones for basket-ground communication
- Main and auxiliary motor start / stop control from the basket
- Multifunction radio remote control for emergency control of the aerial part from the ground and stabilization
- Automatic PTO deactivation
- 2 fixed roto-lamp on the vehicle cabin
- Socket 230V / 400V
- Heat exchanger on the hydraulic system
- 2 folding sides, 2 fixed (h 150 mm)
- 4 plates to stand to the ground
- Anti-corrosion treatment on unpainted components

SAFETY DATA

- Emergency and stop button
- Cross check of open stabilizers
- Anemometer
- Load limiter in the basket
- Moment limiter with double safety and control of correct operation
- Multi axial device for visual control of frame stabilization
- Emergency descent with electric pump (in the absence of the auxiliary motor)
- Rotation brake of the turret with automatic insertion
- Hydraulic system with differentiated filtering with high efficiency filters both on the delivery lines and on the return lines
- Multifunction radio control for emergency control
- Automatism for rotation lock with extension of the stabilizers on one side only
- Chassis flatness sensor
- Flanged block valves

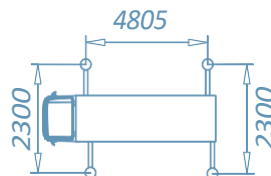
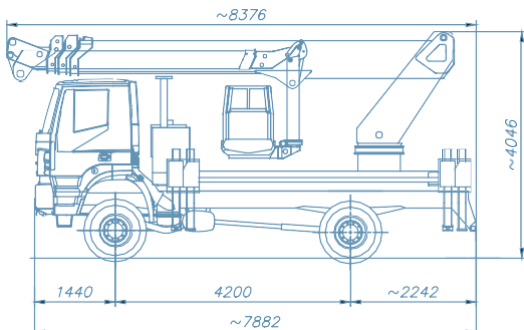

OUTRIGGERS Extensible HE+HE	WORKING HEIGHT 34.8 mt	BASKET HEIGHT 32.8 mt	MAX OUTREACH 21.9 mt	BASKET LOAD CAPACITY 400 kg
BASKET SIZE 2300/3600x900x1100 mm	CONTROLS Electric	TURRET ROTATION 700°	GW 16 ton	





SOCAGE, AERIAL PLATFORM CONSTRUCTOR ALL OVER THE WORLD



Socage, based in Modena, Italy, produces and sells truck mounted Aerial Working Platforms all over the world. With more than 40 years of experience, Socage is among the top experienced companies in the field.

Our products are of high quality and technologically advanced. Most notably, we stand out in the market for our reliability, ease of use, and performance.



forSte.it



MY SOCAGE

From your smartphone, tablet or pc via My Socage you can:

- Connect your platforms to Socage's software
- Find spare parts quickly and easily
- Request remote diagnosis via Socage Connect
- Manage the working hours of your platforms

My Socage connects your platforms with what matters the most to you.

Welcome to Socage Universe

