



**CONVERTIBLE HEAVY DUTY  
FIFTH WHEEL COUPLING**



## CONVERTIBLE HEAVY DUTY FIFTH WHEEL COUPLING

Hyva FW20 and FW21 are specially designed for heavy duty market applications, with **higher vertical load**, **strong carrying capacity** and **high safety performance**.

The Fifth Wheel family includes two convertible models, a 3.5" and a 2" version.

### PRODUCT FEATURES

- **Special reinforced Hyva design for Fifth Wheel plate**
- **The rubber bearings are suitable for tough road conditions, shock-absorbing and maintenance-free**
- **Retrofittable from 2" or 3½", only the wear ring and locking jaw have to be exchanged**
- **Reinforced cast pedestal structure, easy disassembly and replacement of rubber bearings**
- **Approved according ECE R55-02 regulation** 



### SPECIFICATIONS

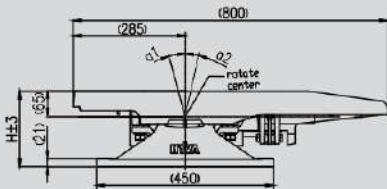

| PRODUCT TYPE         | FW20           | FW21           |
|----------------------|----------------|----------------|
| ORDER NO.            | FW2016000      | FW2116000      |
|                      | FW2019000      | FW2119000      |
|                      | FW2025000      | FW2125000      |
| Kingpin              | 3.5"           | 2"             |
| Imposed load (t)     | 38.5           | 25             |
| D value (kN)         | 260            | 230            |
| Mounting height (mm) | 160/190/250    | 160/190/250    |
| Weight (kg)          | 181/187/210    | 182/188/211    |
| Bearing arrangement  | Rubber bearing | Rubber bearing |
| ECE R55 approval     | E32-55R02-0215 | E32-55R02-0216 |

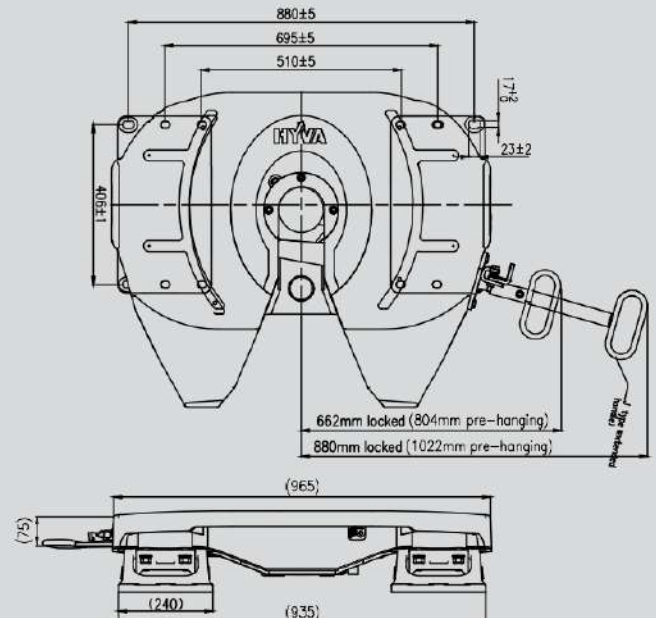

**PART LIST**



**Fifth Wheel coupling part list**

| No. | Description                          | Part no. | Qty. | Remark  |
|-----|--------------------------------------|----------|------|---|
| 1   | 902 Wearing ring subassembly 3.5"    | HSF00030 | 1    | Wearing ring 3.5" + Hexagon socket screw  |
|     | 902 Wearing ring subassembly 2"      | HSF00031 | 1    | Wearing ring 2" + Hexagon socket screw  |
| 2   | 902 Lock jaw subassembly 3.5"        | HSF00032 | 1    | Lock jaw 3.5" + Small tension spring  |
|     | 902 Lock jaw subassembly 2"          | HSF00033 | 1    | Lock jaw 2" + Small tension spring  |
| 3   | 902 locking bar                      | HSF00034 | 1    | -   |
| 4   | 902 Lever plate                      | HSF00035 | 1    | -   |
| 5   | 902 Pull handle                      | HSF00036 | 1    | -   |
| 6   | 902 Adjusting screw subassembly      | HSF00037 | 1    | Adjusting screw + Hexagon head nut  |
| 7   | Handle groove plate subassembly      | HSF00038 | 1    | Handle groove plate + Hexagon bolt + Lock nut   |
| 8   | Latch subassembly                    | HSF00039 | 1    | Latch + Torsion spring + Flat washer + Hexagon head screw + Hexagon head nut  |
| 9   | Cover plate                          | HSF00040 | 2    | -   |
| 10  | Rubber bushing subassembly           | HSF00041 | 2    | Upper rubber bearing + Lower rubber bearing   |
| 11  | 902 Locking bar bolt subassembly     | HSF00042 | 1    | Locking bar bolt + Spacer sleeve + Big torsion spring + Flat washer + Split pin   |
| 12  | Lever cover plate subassembly        | HSF00043 | 1    | Lever cover plate + Hexagon bolt + Flat washer + Elastic washer   |
| 13  | 902 Locking jaw bolt                 | HSF00044 | 1    | -   |
| 14  | 90 Double Spring subassembly         | HSF00045 | 1    | Outer tension spring + Inner tension spring   |
| 15  | 160mm Pedestal                       | HSF00048 | 2    | Applied in fifth wheel couplings type FW20 and FW21 160 mm height   |
|     | 190mm Pedestal                       | HSF00047 | 2    | Applied in fifth wheel couplings type FW20 and FW21 190 mm height   |
|     | 250mm Pedestal                       | HSF00049 | 2    | Applied in fifth wheel couplings type FW20 and FW21 250 mm height   |
| 16  | Lock jaw greasing kit                | HSF00050 | 1    | Dust cap + Inner and outer wire joint + Grease nozzle + Thin nut + Grease tube + Union joint + Sealing ring   |
| 17  | Grease supply subassembly            | HSF00051 | 1    | Dust cap + Inner and outer wire joint + Grease nozzle + Thin nut + Grease tube + Union joint + Positioning distributor + Sealing ring + Combination screw |
| 18  | Release lever subassembly            | HSF00052 | 1    | Release lever + Small tension spring  |
| 19  | Release lever screw bolt subassembly | HSF00053 | 1    | Hexagon bolt + Lock nut   |
| 20  | Cover plate screw bolt subassembly   | HSF00054 | 8    | Hexagon bolt + Elastic washer   |

**110 countries**  
**+3,500 employees**  
**20,000 customers**  
**+30 subsidiaries**  
**14 production facilities**



**Hyva is a leading provider of innovative and highly efficient transport solutions for commercial vehicles used in transport, construction, mining, materials handling and environmental service industries.**

**Founded in 1979 in the Netherlands, the company has a global presence with more than 30 wholly owned subsidiaries, extraordinary service coverage and 14 manufacturing facilities in Brazil, China, Europe and India.**

**For more information on Hyva, please visit [www.hyva.com](http://www.hyva.com)**

**or follow us on:**



**Hyva Holding B.V.**  
Antonie van Leeuwenhoekweg 37  
2408 AK Alphen aan den Rijn  
The Netherlands  
Telephone: +31 (0)172 - 42 35 55  
Telefax: +31 (0)172 - 42 08 80  
info@hyva.com  
www.hyva.com



**DEALER STAMP**